

ENGINEERING data
STUFFING BOX

"RNL" STUFFING BOX (7/8 thru 2-7/16 shafts)

Standard Ports

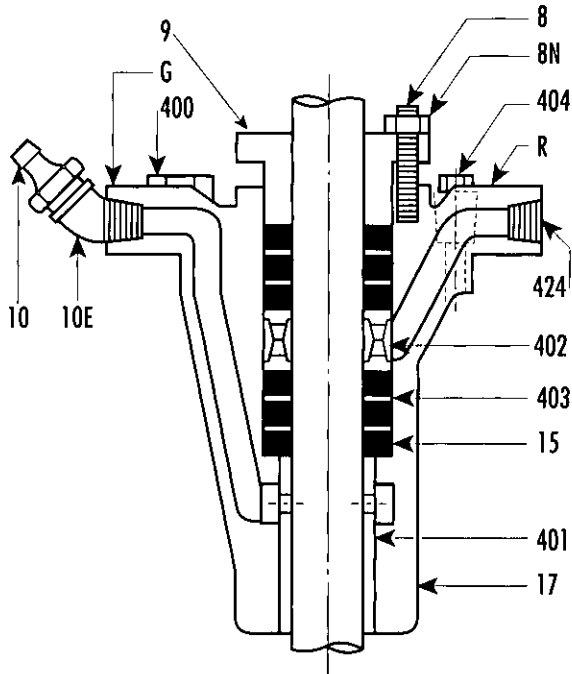

ITEM. NO.	PART NAME	MATERIAL	
		STD.	OPTIONAL
17A	STUFFING BOX ASSY	—	—
8	STUD, SPLIT GLAND	STN. STL.	—
8N	HEX NUT, SPLIT GLAND	BRASS	—
9	SPLIT GLAND	BRONZE	—
10	ALEMITE FITTING	—	—
10E	STREET ELL	C.I.	—
15	PACKING (6 RINGS)	ACRYLIC	—
17	STUFFING BOX	C.I. CL30	—
400	CAPSCREW, ST. BOX/HD.	STEEL	—
401	BEARING, ST. BOX	BRONZE	—
402	LANTERN RING	TEFLON ■	—
403	SEPARATOR RING (4)	TEFLON ●	—
404	PLUG, PRE-LUBE CONN.	C.I.	—
424	RELIEF PORT, 1/4 NPT	—	—
G	PORT MARKING	—	—
R	PORT MARKING	—	—

■ Mat'l. - Bronze on 2-3/16 & 2-7/16 Sizes

● Mat'l. - Bronze on 3x1 Size (RNL 31).

▲ Size Conn. - 3x7/8 & 1 = 1/4 NPT, 4x7/8 Thru 1-1/2 & 6x7/8 & 1 = 1/2 NPT, 6x1-3/16 Thru 2-7/16 = 3/4 NPT.

SHAFT SIZE	MAX. RATING		SHAFT SIZE	MAX. RATING	
	PSI	FT./HD.		PSI	FT./HD.
7/8	150	346	1-11/16	125	289
1	150	346	1-15/16	125	289
1-3/16	150	346	2-3/16	100	231
1-1/2	125	289	2-7/16	100	231

Reverse ports

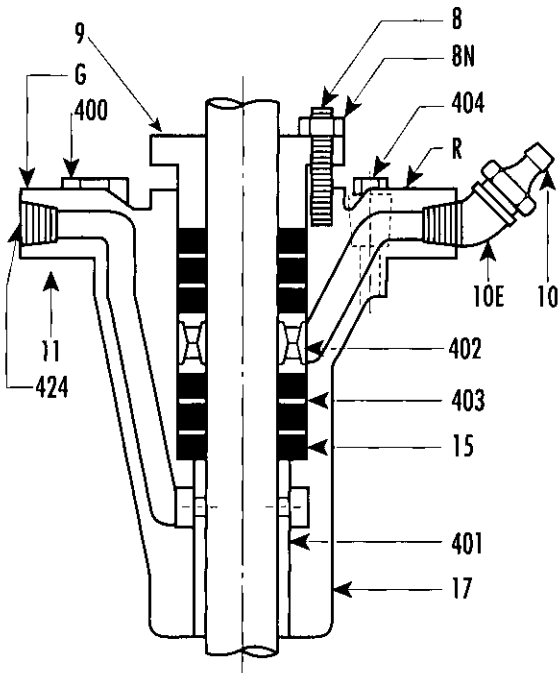

ITEM. NO.	PART NAME	MATERIAL	
		STD.	OPTIONAL
17A	STUFFING BOX ASSY	—	—
8	STUD, SPLIT GLAND	STN. STL.	—
8N	HEX NUT, SPLIT GLAND	BRASS	—
9	SPLIT GLAND	BRONZE	—
10	ALEMITE FITTING	—	—
10E	STREET ELL	C.I.	—
11	GASKET ST. BOX/HD.	—	—
15	PACKING (6 RINGS)	ACRYLIC	—
17	STUFFING BOX	C.I. CL30	—
400	CAPSCREW, ST. BOX/HD.	STEEL	—
401	BEARING, ST. BOX	BRONZE	—
402	LANTERN RING	TEFLON ■	—
403	SEPARATOR RING (4)	TEFLON ●	—
404	PLUG, PRE-LUBE CONN.	C.I.	—
424	RELIEF PORT, 1/4 NPT.	—	—
G	PORT MARKING	—	—
R	PORT MARKING	—	—

■ Mat'l. - Bronze on 2-3/16 & 2-7/16 Sizes

● Mat'l. - Bronze on 3x1 Size (RNL 31)

▲ Size Conn. - 3x7/8 & 1 = 1/4 NPT, 4x7/8 Thru 1-1/2 & 6x7/8 & 1 = 1/2 NPT, 6x1-3/16 Thru 2-7/16 = 3/4 NPT

SHAFT SIZE	MAX. RATING		SHAFT SIZE	MAX. RATING	
	PSI	FT./HD.		PSI	FT./HD.
7/8	225	520	1-11/16	200	462
1	225	520	1-15/16	200	462
1-3/16	225	520	2-3/16	175	410
1-1/2	200	462	2-7/16	175	410



ENGINEERING data
STUFFING BOX

"RNL" STUFFING BOX (With O'Ring Mounted Sleeve)
7/8 thru 2-3/16 shafts x 1 thru 2-7/16 O.D. sleeves

Standard Ports

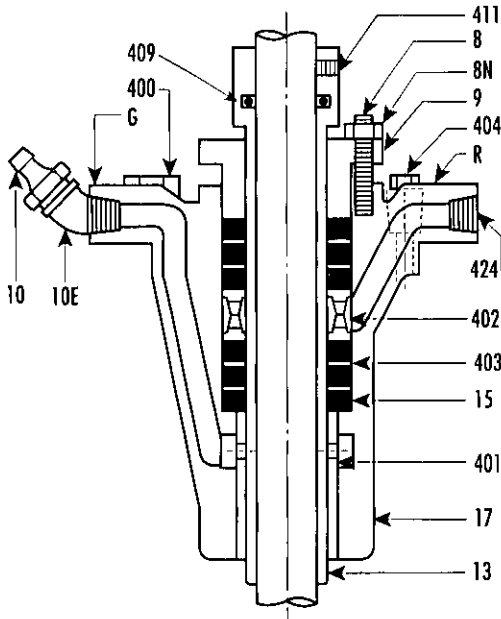

* SIZE CONN - 3x1 = 1/4 NPT, 4x1 thru 1-1/2 & 6x1 = 1/2 NPT, 6x1-3/16 thru 6x2-7/16=3/4 NPT

ITEM. NO.	PART NAME	MATERIAL	
		STD.	OPTIONAL
17A	STUFFING BOX ASSY	—	—
8	STUD, SPLIT GLAND	STN STL	—
8N	HEX NUT, SPLIT GLAND	BRASS	—
9	SPLIT GLAND	BRONZE	—
10	ALEMITE FITTING	—	—
10E	STREET ELL	C I	—
15	PACKING (6 RINGS)	ACRYLIC	—
17	STUFFING BOX	C I CL30	—
400	CAPSCREW, ST. BOX, HD	STEEL	—
401	BEARING, ST BOX	BRONZE	—
402	LANTERN RING	TEFLON ■	—
403	SEPARATOR RING (4)	TEFLON ●	—
* 404	PLUG, PRE-LUBE CONN	C I	—
424	RELIEF PORT, 1/4 NPT	—	—
G	PORT MARKING	—	—
R	PORT MARKING	—	—
13A	SLEEVE ASSY	—	—
13	SLEEVE ST BOX	316SS▲	—
409	O' RING, SLEEVE	RUBBER	—
411	SET SCREW, SLEEVE	STN STL	—

SHAFT SIZE	SLEEVE SIZE	MAX. RATING		SHAFT SIZE	SLEEVE SIZE	MAX. RATING	
		PSI	FT./HD.			PSI	FT./HD.
7/8	1	150	396	1-11/16	1-15/16	125	289
1	1-3/16	150	396	1-15/16	2-3/16	100	231
1-3/16	1-1/2	125	289	2-3/16	2-7/16	100	231
1-1/2	1-11/16	125	289				

- Mat'l. - Bronze on 2-3/16 & 2-7/16 Sizes
- Mat'l - Bronze on 3x1 Size (RNL 31).
- ▲ Optional Mat'l. - 316SS w/nickle chrome coating (600 Brinell hardness)

Reverse Ports

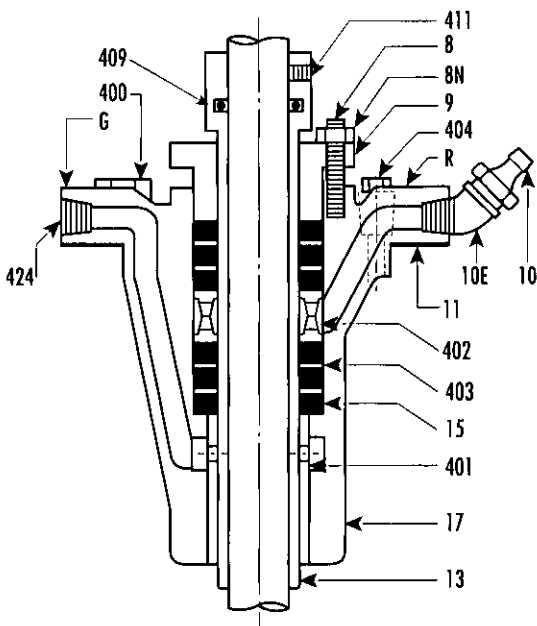

* SIZE CONN - 3x1 = 1/4 NPT, 4x1 thru 1-1/2 & 6x1 = 1/2 NPT, 6x1-3/16 thru 6x2-7/16=3/4 NPT

ITEM. NO.	PART NAME	MATERIAL	
		STD.	OPTIONAL
17A	STUFFING BOX ASSY	—	—
8	STUD, SPLIT GLAND	STN STL	—
8N	HEX NUT, SPLIT GLAND	BRASS	—
9	SPLIT GLAND	BRONZE	—
10	ALEMITE FITTING	—	—
10E	STREET ELL	C I	—
11	GASKET ST BOX/HD	—	—
15	PACKING (6 RINGS)	ACRYLIC	—
17	STUFFING BOX	C I CL30	—
400	CAPSCREW, ST BOX/HD	STEEL	—
401	BEARING, ST BOX	BRONZE	—
402	LANTERN RING	TEFLON ■	—
403	SEPARATOR RING (4)	TEFLON ●	—
* 404	PLUG, PRE-LUBE CONN.	C I	—
424	RELIEF PORT, 1/4 NPT	—	—
G	PORT MARKING	—	—
R	PORT MARKING	—	—
13A	SLEEVE ASSY	—	—
13	SLEEVE ST BOX	316SS▲	—
409	O' RING, SLEEVE	RUBBER	—
411	SET SCREW, SLEEVE	STN STL	—

SLEEVE SIZE	MAX. RATING		SLEEVE SIZE	MAX. RATING	
	PSI	FT./HD.		PSI	FT./HD.
7/8	225	520	1-11/16	200	462
1	225	520	1-15/16	175	410
1-3/16	200	462	2-3/16	175	410
1-1/2	200	462			

- Mat'l. - Bronze on 2-3/16 & 2-7/16 Sizes
- Mat'l - Bronze on 3x1 Size (RNL 31)
- ▲ Optional Mat'l. - 316SS w/nickle chrome coating (600 Brinell hardness)



"RNL" STUFFING BOX

READ THOROUGHLY BEFORE PROCEEDING

ASSEMBLY

1. CLEAN THE STUFFING BOX AND THE MATING PORTION OF THE DISCHARGE HEAD THOROUGHLY AND REMOVE ANY NICKS AND BURRS FROM MATING FLANGE SURFACES AND REGISTERS. MAKE CERTAIN THAT THE GREASE AND RELIEF PORTS ARE OPEN AND CLEAN. INSTALL THE STUFFING BOX IN THE HEAD, ORIENTATE THE RELIEF AND GREASE PORTS AS REQUIRED, AND INSTALL AND EVENLY TIGHTEN THE MOUNTING CAPSCREWS. IF A FLAT GASKET IS FURNISHED, MAKE CERTAIN THAT THE CAPSCREWS ARE TORQUED EQUALLY TO PREVENT MISALIGNMENT.
2. INSTALL THE PACKING, SEPARATOR RINGS, AND THE LANTERN RING AS SHOWN ON THE DRAWING MAKING CERTAIN THAT THE PACKING RING JOINTS ARE STAGGERED. TO HELP SEAL THE PACKING PROPERLY, EACH PACKING RING WITH A SEPARATOR RING (OR LANTERN RING) ON TOP SHOULD BE TAMPED IN WITH A BUSHING OR A PIECE OF PIPE OR TUBE AS IT IS INSTALLED.
3. INSTALL THE PACKING GLAND AND TIGHTEN SUFFICIENTLY TO FINISH SEATING THE PACKING, THEN LOOSEN TO A LITTLE BETTER THAN HAND TIGHT.
4. DETERMINE THE APPROXIMATE PRESSURE THE STUFFING BOX WILL BE SUBJECTED TO DURING NORMAL OPERATION. THIS WILL DICTATE WHETHER THE PORTS SHOULD BE SET-UP AS STANDARD OR REVERSED. THE PRESSURE LIMITATIONS FOR BOTH PORTING ARRANGEMENTS ARE LISTED ON THE DRAWING.
5. CONNECT THE GREASE FITTING AND THE STREET ELL TO THE PROPER PORT AS DETERMINED IN THE ABOVE STEP. PUMP GREASE INTO THE STUFFING BOX. USE 'LAYNE GREASE' OR EQUAL FOR BEST RESULTS.
6. LEAVE THE REMAINING PORT (RELIEF PORT) OPEN AT THIS TIME. THE DECISION TO EITHER LEAVE THE PORT OPEN, PLUG IT, ADD RELIEF PIPING AND/OR A THROTTLE VALVE MUST BE DETERMINED AFTER START-UP AND IS COVERED UNDER "OPERATION & MAINTENANCE" BELOW.

OPERATION & MAINTENANCE

1. AFTER INITIAL START-UP, MAKE CERTAIN THAT THE UNIT RUNS SUFFICIENTLY LONG TO SEAL THE PACKING. THIS USUALLY TAKES AN HOUR OR SO.
2. THE DISPOSITION OF THE RELIEF PORT SHOULD BE DETERMINED AS FOLLOWS:
 - A. STANDARD PORTING SET-UP (PORT MARKED "R").
 1. IF LEAKAGE IS EXCESSIVE AT THE GLAND EVEN WITH THE RELIEF PORT WIDE OPEN, FIRST TIGHTEN THE GLAND TO REDUCE LEAKAGE BUT NOT SUFFICIENTLY TO CAUSE THE GLAND TO BECOME HOT. IF LEAKAGE IS STILL EXCESSIVE, REVERSE THE PORTS AND PROCEED TO THE "REVERSE PORTING SET-UP."
 2. IF THERE IS TOO LITTLE OR NO LEAKAGE AT THE GLAND AND THE GLAND IS HOT TO THE TOUCH, FIRST PLUG THE RELIEF PORT. THIS WILL FORCE WATER PAST THE GLAND. IF LEAKAGE THEN BECOMES EXCESSIVE, TIGHTEN THE GLAND SLIGHTLY, BUT NOT SUFFICIENTLY TO ALLOW OVER HEATING.
 3. IF LEAKAGE IS STILL EXCESSIVE, REMOVE THE RELIEF PORT PLUG AND INSTALL A THROTTLE VALVE, COPPER TUBING OR BOTH. CLOSE DOWN SLOWLY ON THE VALVE OR SLOWLY PINCH THE COPPER TUBING DOWN UNTIL THE PROPER AMOUNT OF LEAKAGE OCCURS PAST THE GLAND (USUALLY A SMALL STEADY STREAM).
 - B. REVERSE PORTING SET-UP (PORT MARKED "G").
 1. IF LEAKAGE IS EXCESSIVE EVEN WITH THE RELIEF PORT WIDE OPEN, FIRST TIGHTEN THE GLAND SLIGHTLY BUT NOT ENOUGH TO CAUSE THE GLAND TO BECOME HOT. IF LEAKAGE IS STILL EXCESSIVE EITHER: 1. TOLERATE THE EXCESSIVE LEAKAGE; 2. REMOVE THE GREASE CUP AND INSTALL A SECONDARY RELIEF LINE; 3. REPLACE STUFFING BOX WITH A HIGH PRESSURE UNIT.
 2. IF THERE IS TOO LITTLE OR NO LEAKAGE PAST THE GLAND, INSTALL A THROTTLE VALVE, COPPER TUBING OR BOTH IN THE RELIEF PORT. SLOWLY CLOSE DOWN THE VALVE OR PINCH OFF THE COPPER TUBE UNTIL THE PROPER AMOUNT OF LEAKAGE OCCURS PAST THE GLAND (USUALLY A SMALL STEADY STREAM).
3. DURING THE FIRST FOUR OR FIVE HOURS OF OPERATION, PERIODICALLY OBSERVE THE LEAKAGE AND FEEL THE GLAND. IF NECESSARY, LOOSEN THE GLAND TO RESTORE LEAKAGE TO THE DESIRED RATE OR TO PREVENT THE GLAND FROM OVERHEATING. THE WATER LEAKING PAST THE GLAND SHOULD NOT BE ALLOWED TO BECOME HOT ENOUGH TO STEAM. IF THE PACKING IS ALLOWED TO OVERHEAT, IT WILL SCORE THE SHAFT (OR SLEEVE), REQUIRING REPLACEMENT OF THE PACKING AND THE SHAFT (OR SLEEVE).
4. THE GLAND (AND/OR THE RELIEF VALVE OR LINE IF SO EQUIPPED), MAY HAVE TO BE ADJUSTED PERIODICALLY TO MAINTAIN PROPER OPERATION. WHEN ADJUSTING THE GLAND, DO NOT LOOSEN OR TIGHTEN THE GLAND NUTS MORE THAN 1/8 OF A TURN FOR EVERY TEN (10) MINUTE SPAN. DO NOT COMPLETELY STOP ALL LEAKAGE PAST THE GLAND OR ALLOW THE GLAND TO OVERHEAT.
5. GREASE CAN BE APPLIED AT THE RATE OF ONE TURN FOR EVERY TWENTY-FOUR (24) HOURS OF OPERATION. ON DEEPER SET UNITS WITH THE STANDARD PORTING ARRANGEMENT, IT IS ADVISABLE TO GIVE THE GREASE CUP ONE (1) OR TWO (2) TURNS PRIOR TO EACH START-UP TO LUBRICATE THE STUFFING BOX BEARING.